

ELECTRICAL CONNECTORS

ELECTRICAL DIAGRAM

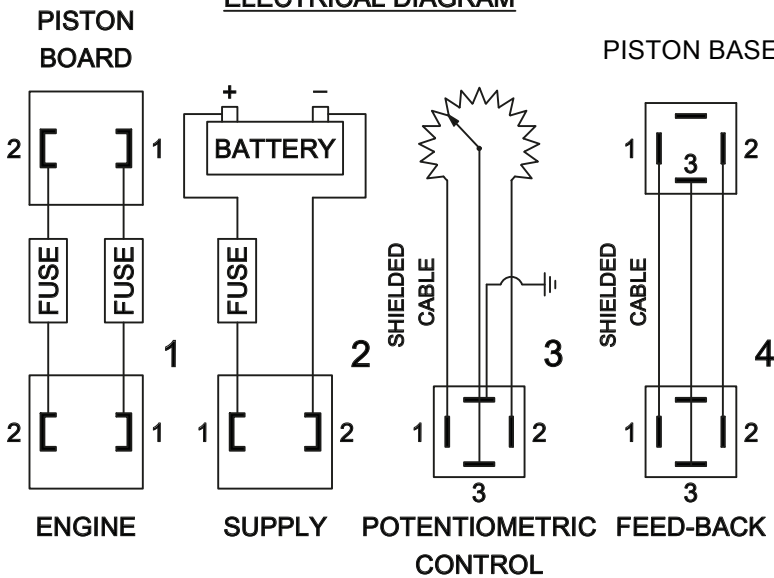

ELECTRONIC CONTROL UNIT FOR MANAGEMENT OF THE ELECTRIC PISTON TYPE PE50P WITH PROPORTIONAL CONTROL

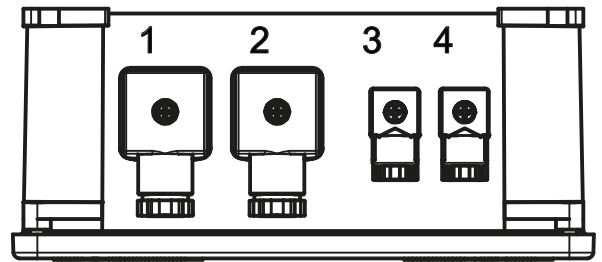

SYSTEM DI ROSATI RESERVES THE RIGHT TO MAKE CHANGES TO THE DIMENSIONS AND CHARACTERISTICS DESCRIBED ON THIS DATA SHEET WITHOUT PRIOR NOTICE.

DATA SHEET

		S.F.C.P
RATED POWER SUPPLY S.F.C.P.V12	V	12
RATED POWER SUPPLY S.F.C.P.V24	V	24
TYPE POWER		VDC
MAX PISTON LOADING CALIBRATION PE50P	N	300
OPERATING TEMPERATURE	°C	from -5 to +60
PROTECTION DEGREE ELECTRONIC CONTROL UNIT	IP	55
TOTAL WEIGHT ELECTRONIC CONTROL UNIT	Kg	1.190